

# REMER

## AMBER 750

### LED SHAVING CABINET

#### SPECIFICATIONS

WIDTH	750mm
HEIGHT	700mm
DEPTH	145mm
WEIGHT	26kg

#### LIGHTING SPECIFICATIONS

CCT	6500K – daylight
CRI	>80

#### INSTALLATION

Wall mount
Hardwired
Input voltage: 220-240v 50Hz
Includes wall mount split batten
Mounting holes are provided for semi-recessed mounting

#### FEATURES

Copper Free Mirror
LED Lighting (6500K)
Touch Sensor
Demister on all Doors
Soft Close
Concealed Wire Technology
Two Adjustable Glass Shelves
Double-Sided Mirror Doors
Recessable up to Door

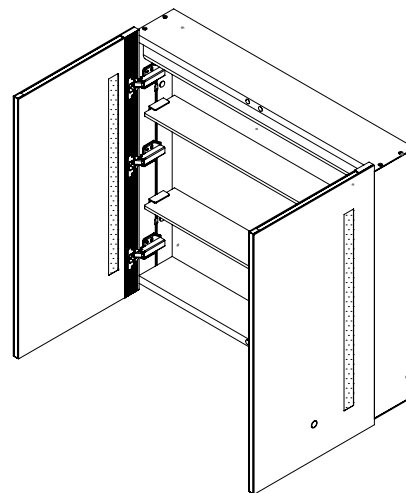

#### FINISH

Silver Aluminium

#### PRODUCT CODE

A75D

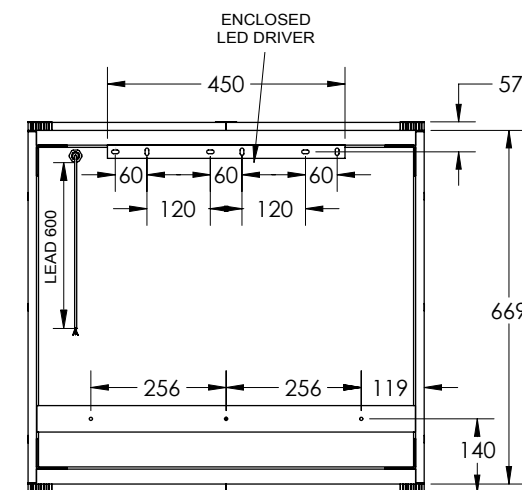
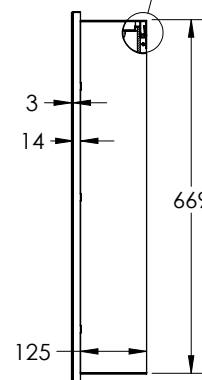
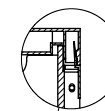
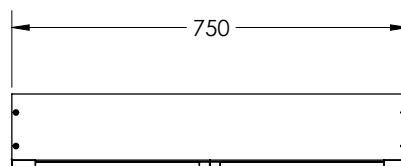
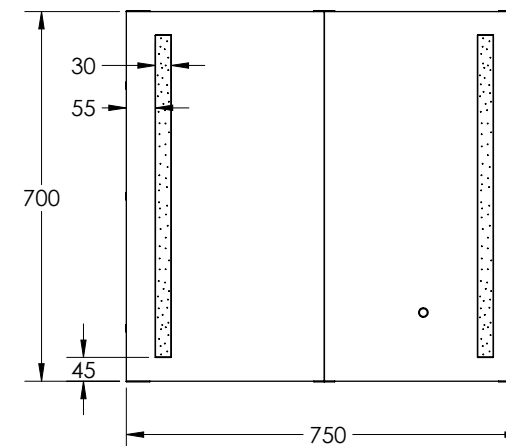

**5 YEAR**  
REPLACEMENT  
WARRANTY

Disclaimer: All LED Products requiring hardwiring must be installed by a licensed electrician in accordance with local regulations. Sizes are in mm and nominal and should be checked prior to installation. Actual colours may vary so please check colour samples before ordering. Installation is acceptance of our products. Installation of faulty, warped, chipped or damaged products will void our warranty.

13-15 Edison Road, Dandenong South VIC 3175  
T (03) 9706 6663 E sales@remer.com.au W remer.com.au

# REMER