



VERA 1500

LED SHAVING CABINET

FINISH

Silver Aluminium

PRODUCT CODE

V150D

SPECIFICATIONS

WIDTH	1500mm
HEIGHT	700mm
DEPTH	145mm
WEIGHT	52kg

FEATURES

- Copper Free Mirror
- LED Lighting (6500K)
- Touch Sensor
- Demister on all Doors
- Soft Close
- Concealed Wire Technology
- Two Adjustable Glass Shelves
- Double-Sided Mirror Doors
- Recessable up to Door

LIGHTING SPECIFICATIONS

CCT	6500K – daylight
CRI	>80

INSTALLATION

- Wall mount
- Hardwired
- Input voltage: 220-240v 50Hz
- Includes wall mount split batten
- Mounting holes are provided for semi-recessed mounting

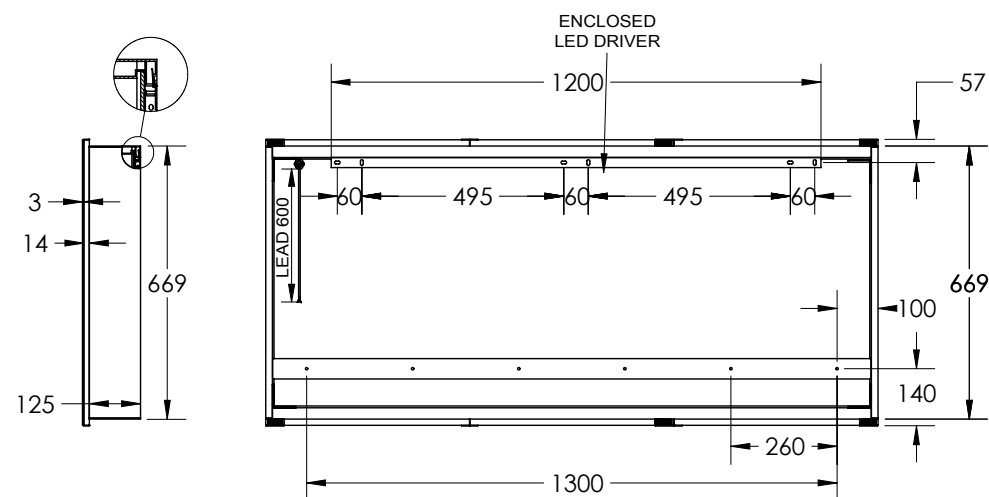
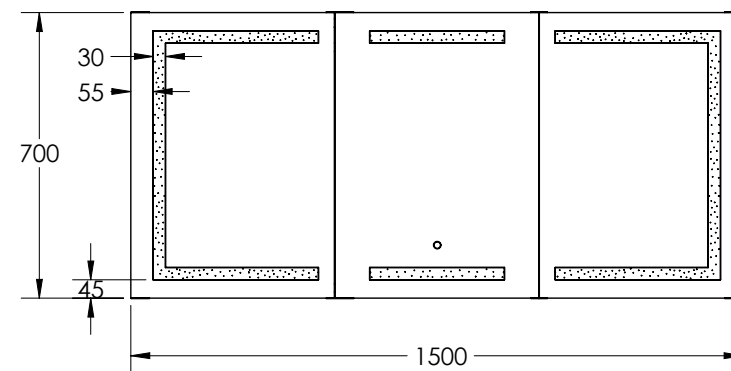
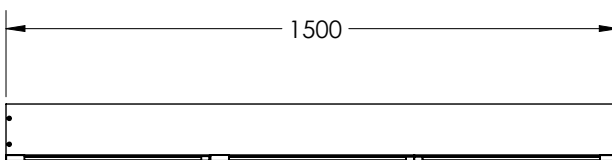

Disclaimer: All LED Products requiring hardwiring must be installed by a licensed electrician in accordance with local regulations. Sizes are in mm and nominal and should be checked prior to installation. Actual colours may vary so please check colour samples before ordering. Installation is acceptance of our products. Installation of faulty, warped, chipped or damaged products will void our warranty.

13-15 Edison Road, Dandenong South VIC 3175
 T (03) 9706 6663 E sales@remer.com.au W remer.com.au

